

DIN69893-1
HSK100-A NORM

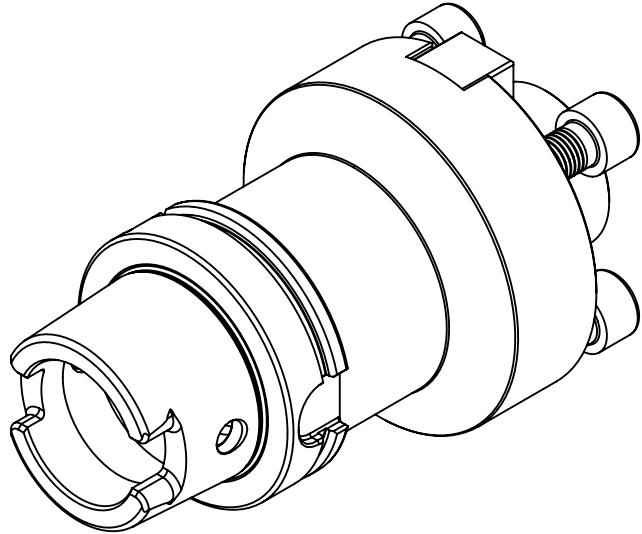

SOĞUTMA DELİĞİ x 2 ADET
COOLANT HOLE x 2 PIECE

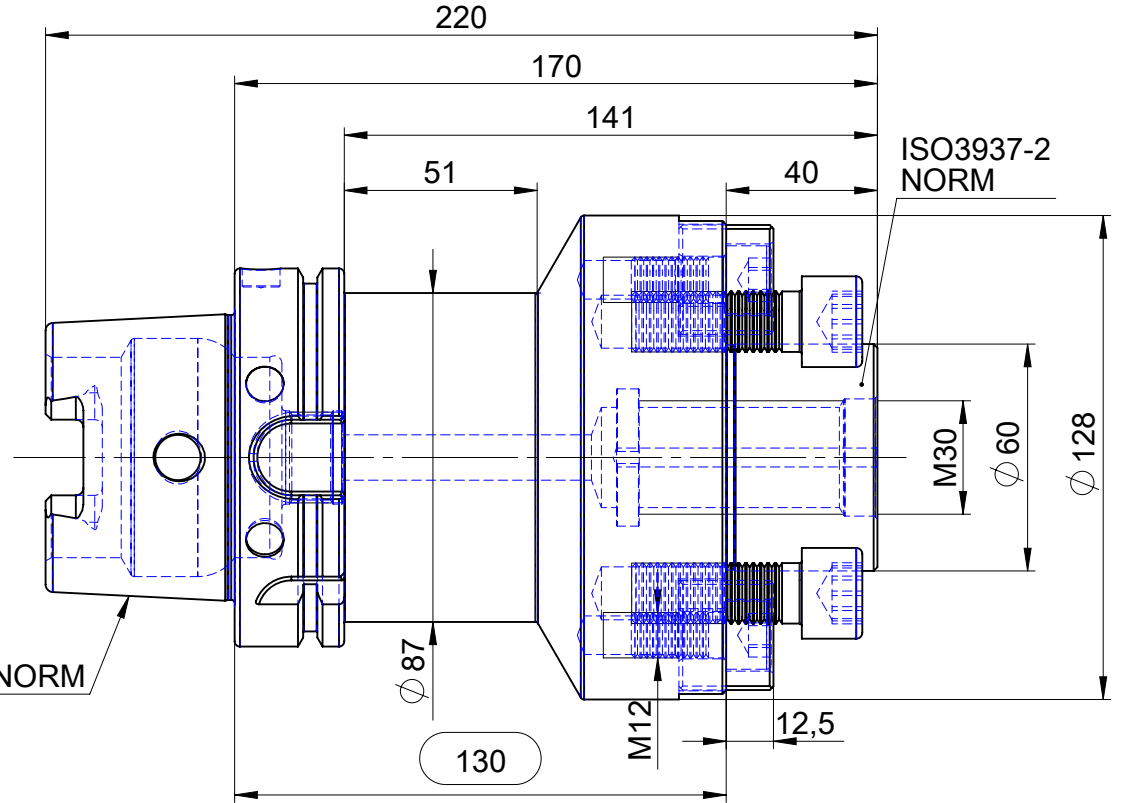
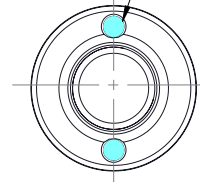

İÇTEN SOĞUTMALI ALIN KAMALI MALAFA
SHELL MILL HOLDER INTERNAL COOLANT

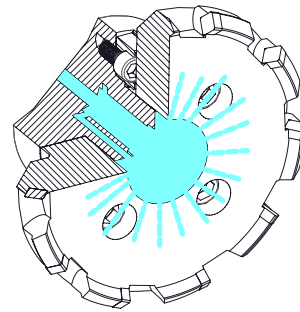

TARAMA BAŞLIĞI SIKMA CIVATASI
DIN 912(ISO 4762) 8.8
DRAWN IN BOLT
DIN 912(ISO 4762) 8.8

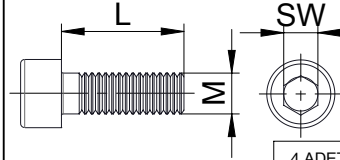

4 ADET
4 PIECE

MxL	SW	Max.Clamping Torque (N.m) Maks.Sıkma Torku (N.m)
M16x45	14	110~135

VİDALI KAMA
DRIVE KEY

b	h	L
25.4	29	25

DIN 912(ISO 4762)
8.8

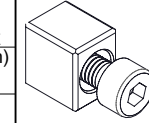

MxL	SW	Max.Clamping Torque (N.m) Maks.Sıkma Torku (N.m)
M12x25	10	69~84



Ürün Adı
Product Name

DIN 69893-1 HSK100-A
SHELL MILL HOLDER
ALIN KAMALI MALAFA

Ürün No
Product No

A100.11.60.130

Üretim No
Production No

80042448

Bu dokümanın tüm hakları EROĞLU MAKİNA A.Ş.'ye aittir.
All rights of this document belongs to EROĞLU MAKİNA A.Ş.